

PRD364JDGU

36-INCH DUAL-FUEL PRO GRAND® RANGE WITH GRIDDLE

PROFESSIONAL SERIES, COMMERCIAL-DEPTH, PORCELAIN COOKTOP SURFACE



FEATURES & BENEFITS

- ★ - Patented Pedestal Star® Burner with QuickClean Base® designed for easy surface cleaning and superior heat spread for any size pan
- ★ - Powerful 22,000 BTU (NG) burner (front right)
- ★ - Precision simmering capabilities as low as 100°F (375 BTU) with 4 ExtraLow® Simmer burners
- ★ - SoftClose® hinges for ultra smooth closing of the oven door
- ★ - Superfast 2-hour self-clean mode—fastest in the industry

TECHNICAL DETAILS

| | |
|------------------------|----------------------------|
| Circuit Breaker (A) | 40 A |
| Volts (V) | 240 / 208 V |
| Frequency (Hz) | 60 Hz |
| Plug Type | No Plug |
| Power Cord Length (in) | Purchase Separately |
| Energy Source | Gas and Electric |
| Gas Type | Natural Gas 15 mbar (USA) |
| Alternative Gas Type | Liquid Gas 27.5 mbar (USA) |

SEE PAGE 2 FOR OPTIONAL ACCESSORIES

GENERAL PROPERTIES

| | |
|--|-----------------------------|
| Oven Capacity | 5.7 cu. ft. |
| Cooking Modes - Main / Large Cavity | |
| Bake, Convection Bake, Broil, Convection Broil, Roast, Convection Roast, Self Clean, Keep Warm | |
| Cooking Modes - Small Cavity | N/A |
| Additional Features | |
| Meat Probe, Sabbath Function, Cook Timer, Kitchen Timer | |
| Cleaning Type | Self Clean |
| Type of Grate | Continuous Cast Iron |
| Controls | Metal Knobs and LCD Display |
| Warming Drawer | No |
| Sealed Burners | Yes |

OVEN PERFORMANCE

| | |
|------------------|---------|
| Bake Power | 2,000 W |
| Broil Power | 4,000 W |
| Convection Power | 2,750 W |

BURNER PERFORMANCE

| | |
|---|---------------------|
| Total Number of Cooktop Burners | 4 + Griddle |
| Power of Front Left Burner BTU | 18,000 and XLO (NG) |
| Power of Back Left Burner BTU | 18,000 and XLO (NG) |
| Power of Back Center Burner BTU | N/A |
| Power of Front Center Burner BTU | N/A |
| Power of Center 12" Electric Griddle (W) | 1,630 W |
| Power of Center 12" Electric Grill (W) | N/A |
| Power of Far Right 12" Electric Griddle (W) | N/A |
| Power of Back Right Burner BTU | 18,000 and XLO (NG) |
| Power of Front Right Burner BTU | 22,000 and XLO (NG) |

DIMENSIONS & WEIGHT

| | |
|---|---------------------------------------|
| Overall Appliance Dimensions (HxWxD) (in) | 35 7/8"–36 3/4" x 35 15/16" x 28 3/4" |
| Required Cutout Size (HxWxD) (in) | 35 7/8"–36 3/4" x 36" x 24"–25 1/8" |
| Adjustable Range Height (in.) | 7/8" |
| Net Weight (lbs) | 360 lbs |

ACCESSORIES (INCLUDED)

1 X Nozzle Set for Liquid Gas, 3 X Telescopic Rack, 1 X Temperature Sensor, 1 X Island Trim, 1 X Grill Plate, 1 X Broiler Pan

WARRANTY

| | |
|---|--------|
| Limited Warranty, Entire Appliance, Parts and Labor | 2 Year |
|---|--------|

PRD364JDGU

36-INCH DUAL-FUEL PRO GRAND® RANGE WITH GRIDDLE

PROFESSIONAL SERIES, COMMERCIAL-DEPTH, PORCELAIN COOKTOP SURFACE



ACCESSORIES (OPTIONAL)

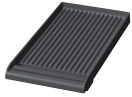

PA12GRILLN
Pro Grill



PAGRIDDLE
Griddle



PA12CVRJ
12" Pro Griddle Cover



PA12CHPBLK
12" Cutting Board



PWOKRINGHC
Wok Ring



PA36JLBG
9" Low Backguard



PA36JTKG
Toekick



PAKNOBLUNG
Blue Knob Pro Grand Kit

36-INCH RANGE AND CUTOUT DIMENSIONS

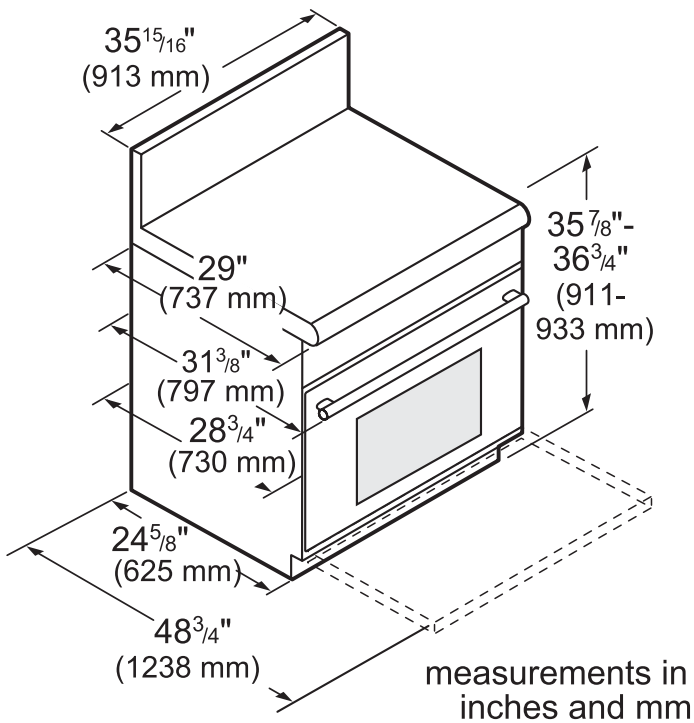

PRD364JDGU

36-INCH DUAL-FUEL PRO GRAND® RANGE WITH GRIDDLE



PROFESSIONAL SERIES, COMMERCIAL-DEPTH, PORCELAIN COOKTOP SURFACE

36-INCH RANGE CUTOUT DIMENSIONS

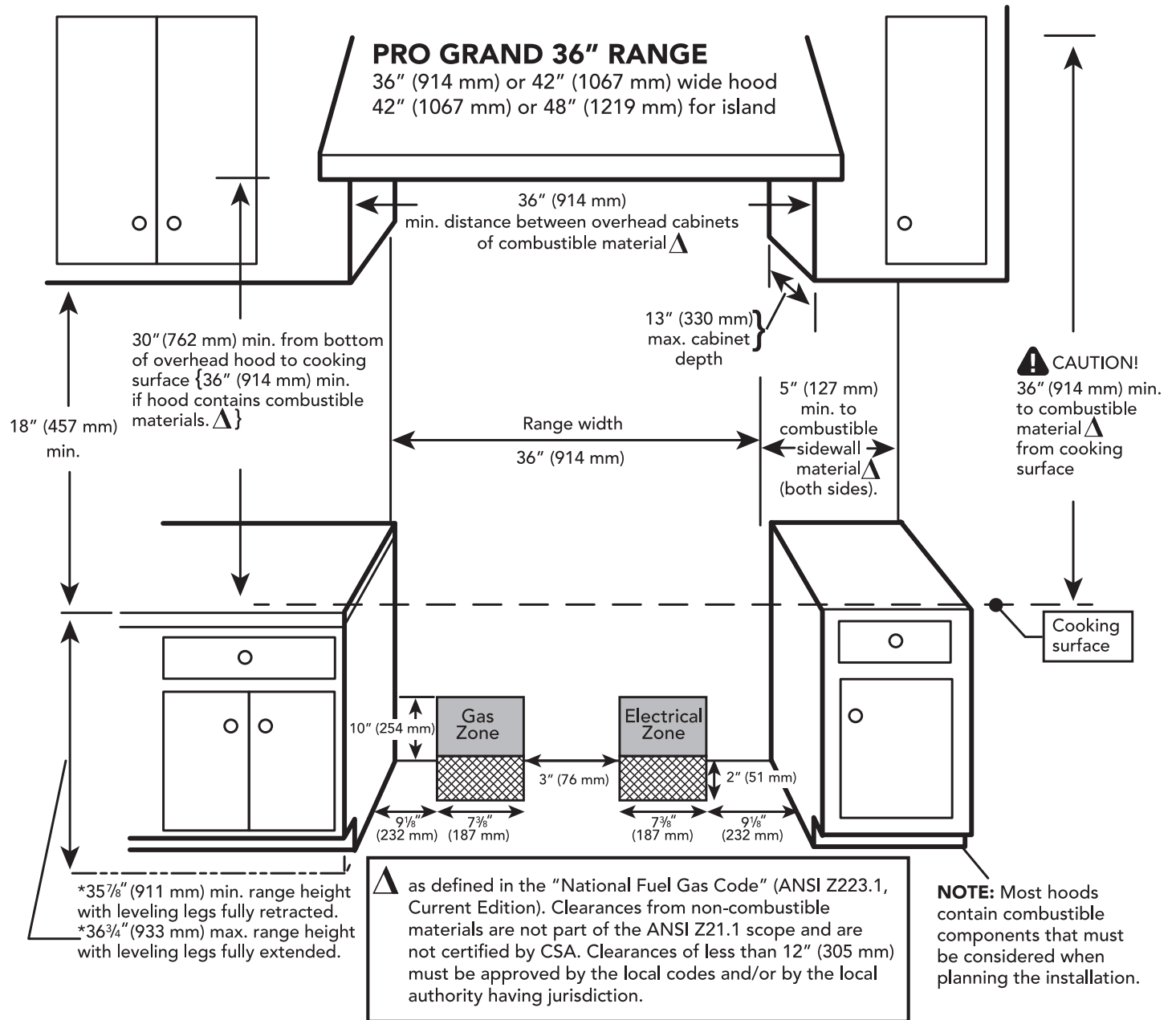

PRD364JDGU

36-INCH DUAL-FUEL PRO GRAND® RANGE WITH GRIDDLE



PROFESSIONAL SERIES, COMMERCIAL-DEPTH, PORCELAIN COOKTOP SURFACE

36-INCH RANGE DIMENSIONS AND CLEARANCE REQUIREMENTS WITH "LOW BACK"

NOTE: A 36-inch minimum clearance is required between the top of the cooking surface and the bottom of an unprotected cabinet. A 30-inch clearance can be used when the bottom of the wood or metal cabinet is protected by not less than 1/4 inch of a flame retardant material covered with not less than No. 28 MSG sheet steel, 0.015 inch (0.4 mm) thick stainless steel, 0.024 inch (0.6 mm) aluminum, or 0.020 inch (0.5 mm) thick copper.

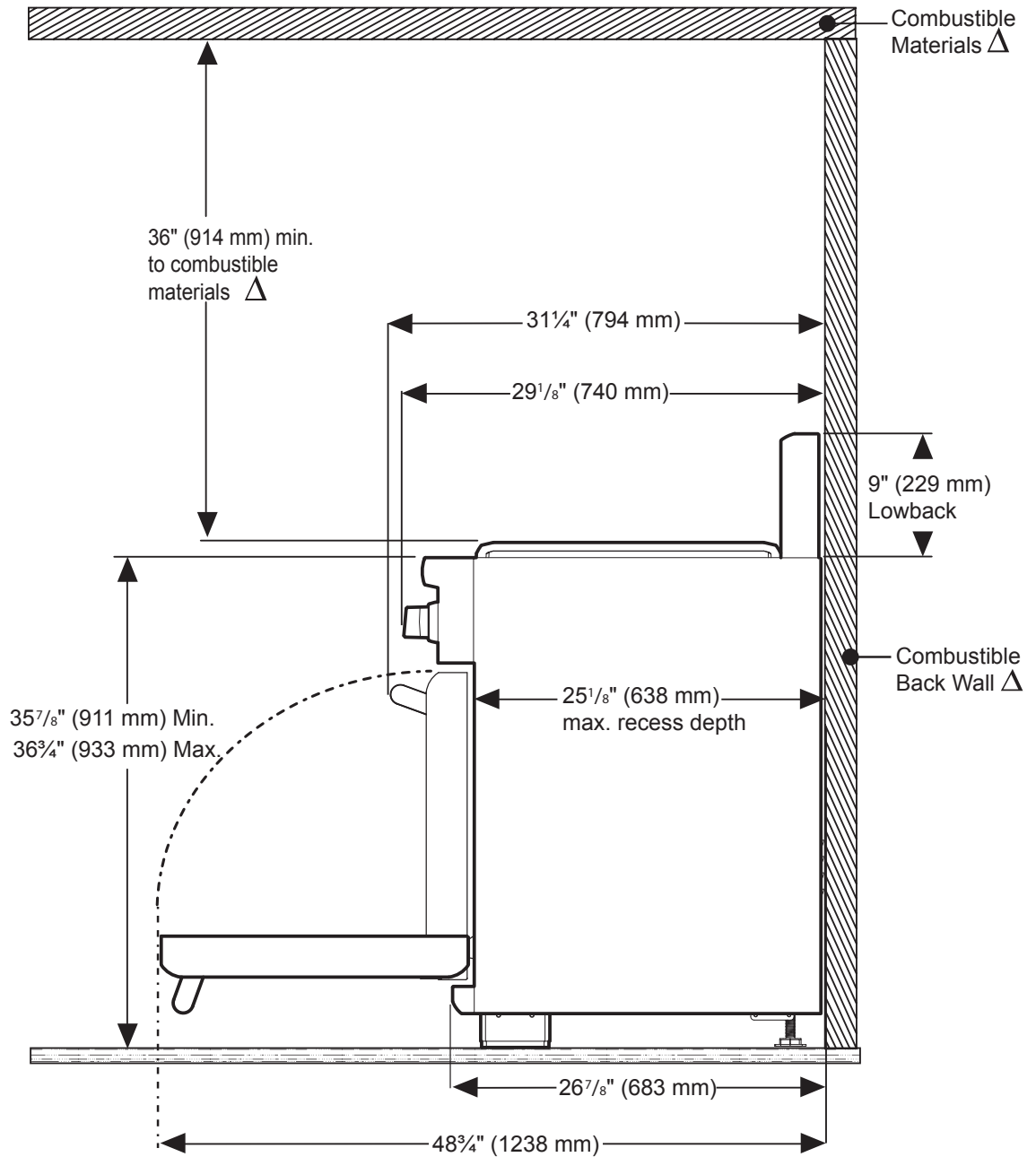

Δ As defined in the "National Fuel Gas Code" (ANSI Z223.1, Current Edition). Clearances from non-combustible materials are not part of the ANSI Z21.1 scope and are not certified by CSA. Clearances of less than 12" (305 mm) must be approved by the local codes and/or by the local authority having jurisdiction.

PRD364JDGU

36-INCH DUAL-FUEL PRO GRAND® RANGE WITH GRIDDLE

PROFESSIONAL SERIES, COMMERCIAL-DEPTH, PORCELAIN COOKTOP SURFACE



36-INCH RANGE DIMENSIONS AND CLEARANCE REQUIREMENTS WITH "FLUSH ISLAND TRIM"

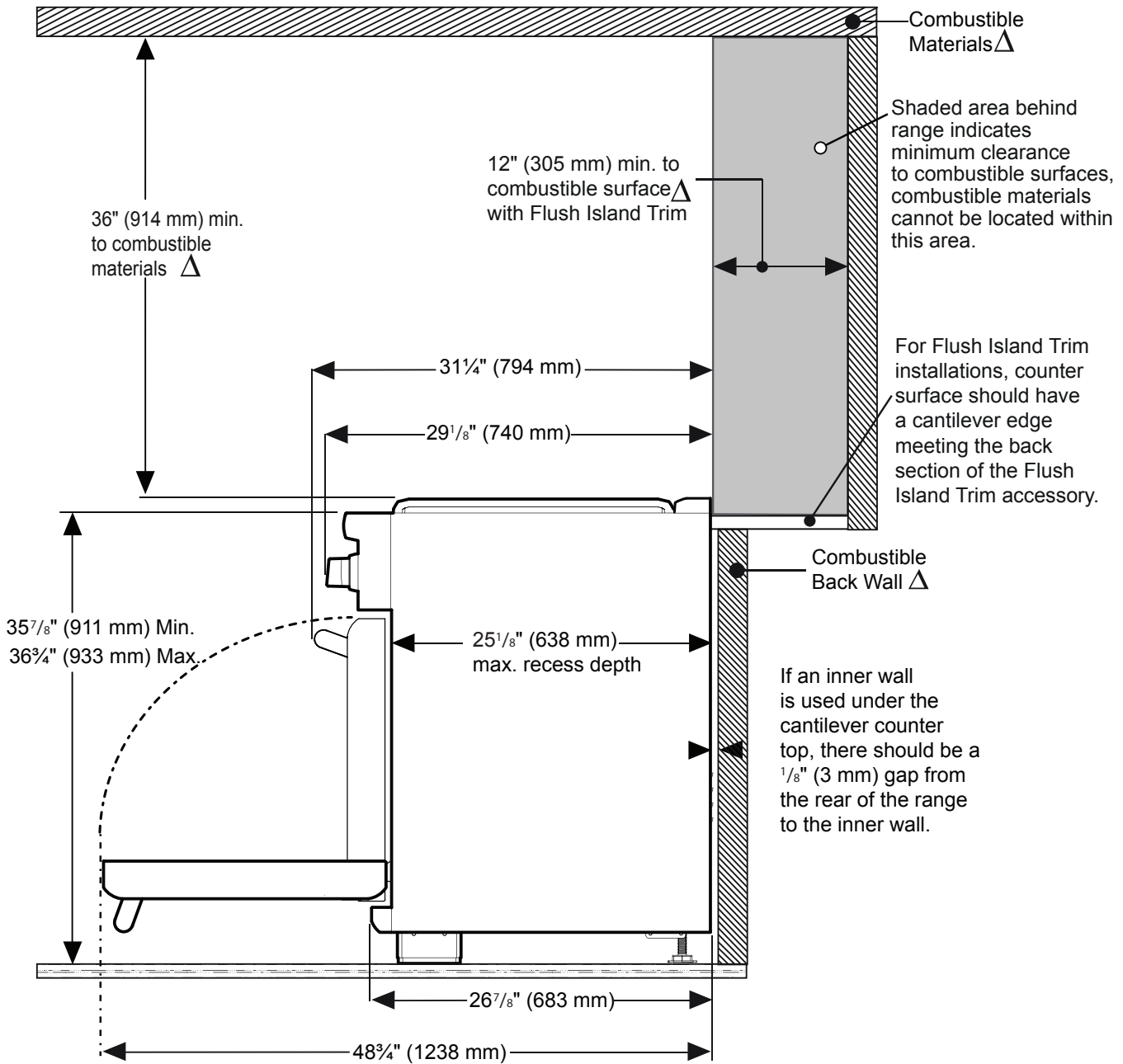

△ As defined in the "National Fuel Gas Code" (ANSI Z223.1, Current Edition). Clearances from non-combustible materials are not part of the ANSI Z21.1 scope and are not certified by CSA. Clearances of less than 12" (305 mm) must be approved by the local codes and/or by the local authority having jurisdiction.

These warranties give you specific legal rights and you may have other rights that vary from state to state. Full warranty and limited warranty from date of installation. For complete warranty details, refer to your Use & Care manual, or ask your dealer.

Specifications are for planning purposes only. Refer to installation instructions and consult your countertop supplier prior to making counter opening. Consult with a heating and ventilation engineer for your specific ventilation requirements. For the most detailed information, refer to installation instructions accompanying product or write to Thermador indicating the model number. Specifications are correct at time of printing. Thermador reserves the right to change product specifications or design without notice. Some models are certified for use in Canada. Thermador is not responsible for products that are transported from the U.S. for use in Canada.